

Digital E-BM-TES/LES drivers

DIN-rail format, for proportional valves with one or two LVDT transducers

E-BM-TES-N- NP Not Present

E-BM-TES-N- BC BP CANopen
PROFIBUS DP

E-BM-TES-S- EH EtherCAT
EW POWERLINK
EI EtherNet/IP
EP PROFINET RT/IRT

Connectors ② included

E-BM-TES/LES

Digital drivers ① control in closed loop the position of the spool or poppet of direct and pilot operated proportional valves, according to the electronic reference input signal.

TES execution controls direct operated directional/flow valves with one LVDT transducer.

LES execution controls pilot operated directional valves with two LVDT transducers.

Option S adds the closed loop control of pressure (SP) or force (SF and SL) to the basic functions of proportional directional valves flow regulation (see section 4.1).

Atos PC software allows to customize the driver configuration to the specific application requirements.

Electrical Features:

- up to 9 fast plug-in connectors ②
- Mini USB port ③ always present
- DB9 fieldbus communication connector ④ for CANopen and ⑤ PROFIBUS DP
- RJ45 ethernet communication connectors ⑥ output and ⑦ input for EtherCAT, POWERLINK, EtherNet/IP, PROFINET
- 8 leds for diagnostics ⑧ (see 6.1)
- Electrical protection against reverse polarity of power supply
- Operating temperature range: $-20 \div +50 \text{ }^\circ\text{C}$
- Plastic box with IP20 protection degree and standard DIN-rail mounting
- CE mark according to EMC directive

Software Features:

- Intuitive graphic interface
- Setting of valve's functional parameters: bias, scale, ramps, dither
- Linearization function for hydraulic regulation
- Setting of PID gains
- Selection of analog IN / OUT range
- Complete diagnostic of driver status
- Internal oscilloscope function
- In field firmware update through USB port

1 MODEL CODE

E-BM	-	TES	-	N	-	NP	-	01H	/	*	/	*	/	*
Off-board electronic driver in DIN rail format									Set code (see section 7)					
TES = digital full driver, for valves with one LVDT transducer LES = digital full driver, for valves with two LVDT transducers									Series number					
Alternated P/Q control: N = none S = closed loop pressure/force (see tech table FS500)									Options, see section 6: A = max current limitation for Ex-proof valves C = current feedback $4 \div 20 \text{ mA}$ for remote transducers (only for option S) and LVDT transducers (only for option A) I = current reference input and monitor $4 \div 20 \text{ mA}$ (omit for voltage reference and monitor input $\pm 10 \text{ Vdc}$)					
Fieldbus interface, USB port always present: NP = Not Present BC = CANopen BP = PROFIBUS DP EH = EtherCAT EW = POWERLINK EI = EtherNet/IP EP = PROFINET RT/IRT									- = omit for direct valves and for pilot operated valves with two LVDT transducers P = for pilot operated valves with one LVDT transducer (only for TES-N)					
01H = for single solenoid proportional valves 05H = for double solenoid proportional valves (only for TES)														

2 BLOCK DIAGRAM EXAMPLE

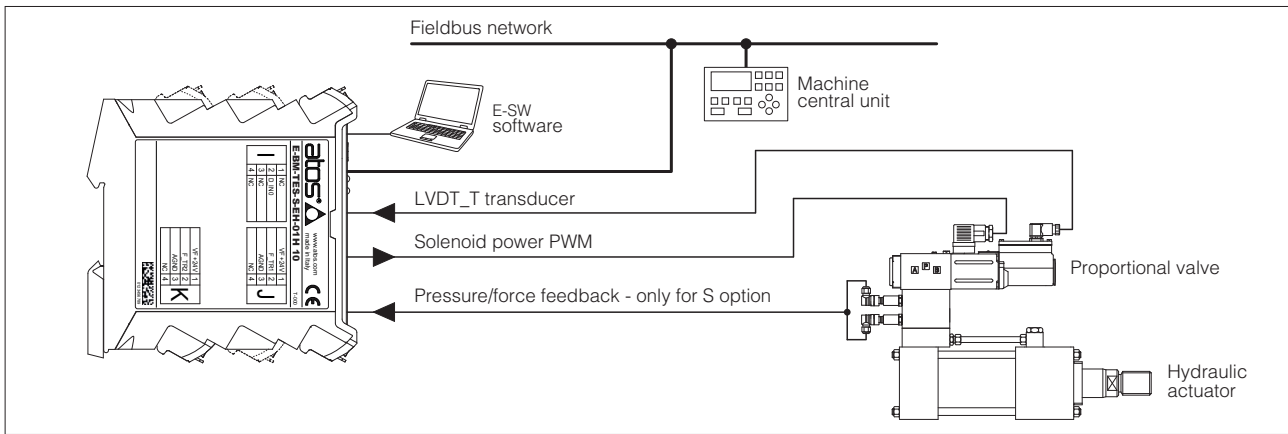

3 VALVES RANGE

Valves	Directional			Flow	Directional	Cartridge
Industrial Tech table	DHZO-T, DKZOR-T F165, F168	DLHZO-T, DLKZOR-T F180	DPZO-T F172	QVHZO-T, QVKZOR-T F412	DPZO-L F175, F178	LIQZO-L, LIQZP-L F330, F340
Ex-proof Tech table	DHZA-T, DKZA-T FX120	DLHZA-T, DLKZA-T FX140	DPZA-T FX220	QVHZA-T, QVKZA-T FX420	-	LIQZA-L FX350, FX370
Driver model	E-BM-TES				E-BM-LES	

Option S not available

4 ALTERNATED P/Q CONTROL - only for S option

S option on digital drivers adds the closed loop control of pressure (SP) or force (SF and SL) to the basic functions of proportional directional valves flow regulation.

The alternated P/Q control operates according to the two electronic reference signals by a dedicated algorithm that automatically selects which control will be active time by time. The dynamics of the switching between the two controls can be regulated thanks to specific software setting, in order to avoid instability or vibrations.

Flow regulation is active when the actual system pressure/force is lower than the relevant input reference signal - the valve works normally to regulate the flow by controlling in closed-loop the spool/poppet position through the integral LVDT transducer.

Pressure/force control is activated when the actual system pressure/force, measured by remote transducers, grows up to the relevant input reference signal - the driver reduces the valve's flow regulation in order to keep steady the system pressure/force. If the pressure/force tends to decrease under its input reference signal, the flow control returns active.

The dynamic response of pressure/force control can be adapted to different system's characteristics, by setting the internal PID parameters using Atos PC software.

Up to 4 different PIDs are selectable to optimize the system dynamic response according to different hydraulic working conditions.

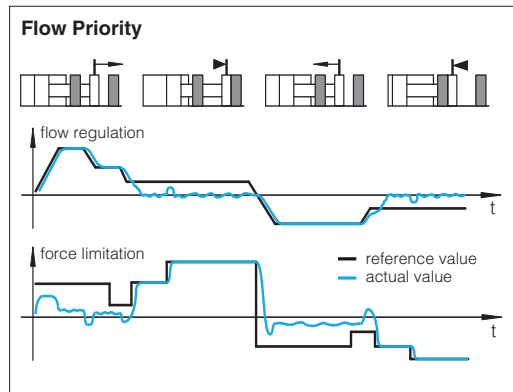

Alternated control configurations - software selectable

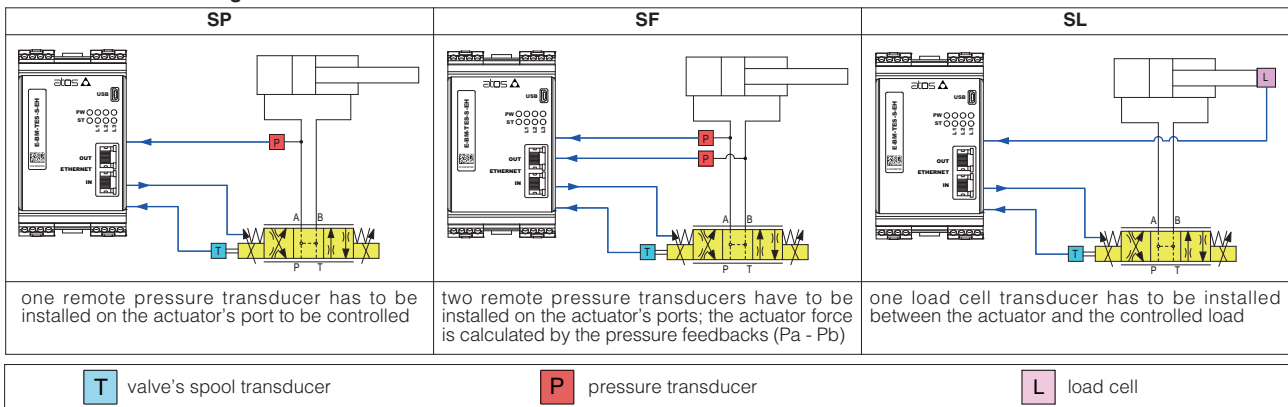

SP – flow/pressure control

Adds pressure control to standard flow control and permits to limit the max force in one direction controlling in closed loop the pressure acting on one side of the hydraulic actuator. A single pressure transducer has to be installed on hydraulic line to be controlled.

SF – flow/force control

Adds force control to standard flow control and permits to limit the max force in two directions controlling in closed loop the delta pressure acting on both sides of the hydraulic actuator. Two pressure transducers have to be installed on both hydraulic line.

SL – flow/force control

Adds force control to standard flow control and permits to limit the max force in one or two directions controlling in closed loop the force performed by the hydraulic actuator. A load cell has to be installed on hydraulic actuator.

General Notes:

- auxiliary check valves are recommended in case of specific hydraulic configuration requirements in absence of power supply or fault - see tech table **EY105**
- for additional information about alternated P/Q controls configuration please refer to tech table **FS500**
- Atos technical service is available for additional evaluations related to specific applications usage

5 MAIN CHARACTERISTICS

Power supplies (see 8.1, 8.2)	Nominal : +24 Vdc Rectified and filtered : $V_{RMS} = 20 \div 32 V_{MAX}$ (ripple max 10 % V_{PP})
Max power consumption	50 W
Current supplied to solenoids	$I_{MAX} = 3,0 A$ for standard driver $I_{MAX} = 2,5 A$ for ex-proof driver (JA option)
Analog input signals (see 8.3, 8.4)	Voltage: range $\pm 10 V_{dc}$ ($24 V_{MAX}$ tollerant) Input impedance: $R_i > 50 k\Omega$ Current: range $\pm 20 mA$ Input impedance: $R_i = 500 \Omega$
Monitor outputs (see 8.5, 8.6)	Output range: voltage $\pm 10 V_{dc}$ @ max 5 mA current $\pm 20 mA$ @ max 500Ω load resistance
Enable input (see 8.7)	Range: $0 \div 5 V_{dc}$ (OFF state), $9 \div 24 V_{dc}$ (ON state), $5 \div 9 V_{dc}$ (not accepted); Input impedance: $R_i > 10 k\Omega$
Digital inputs (see 8.11)	
Fault output (see 8.8)	Output range: $0 \div 24 V_{dc}$ (ON state > [power supply - 2 V] ; OFF state < 1 V) @ max 50 mA; external negative voltage not allowed (e.g. due to inductive loads)
Alarms	Solenoid not connected/short circuit, cable break with current reference signal, over/under temperature, valve spool transducer malfunctions, alarms history storage function
Pressure/Force transducers power supply (only for S option)	+24Vdc @ max 100 mA (E-ATR-8 see tech table GS465)
Format	Plastic box ; IP20 protection degree ; L 35 - H 7,5 mm DIN-rail mounting as per EN60715
Operating temperature	-20 \div +50 °C (storage -25 \div +85 °C)
Mass	Approx. 400 g
Additional characteristics	8 leds for diagnostic; protection against reverse polarity of power supply
Compliance	CE according to EMC directive 2014/30/EU (Immunity: EN 61000-6-2; Emission: EN 61000-6-3) RoHS Directive 2011/65/EU as last update by 2015/65/EU REACH Regulation (EC) n°1907/2006
Communication interface	USB CANopen PROFIBUS DP EtherCAT, POWERLINK, EtherNet/IP, PROFINET IO RT / IRT EC 61158
Communication physical layer	Atos ASCII coding EN50325-4 + DS408 EN50170-2/IEC61158
Communication physical layer	not insulated optical insulated optical insulated Fast Ethernet, insulated 100 Base TX USB 2.0 + USB OTG CAN ISO11898 RS485
Recommended wiring cable	LIYCY shielded cables: 0,5 mm ² max 50 m for logic - 1,5 mm ² max 50 m for power supply Note: for transducers wiring cable please consult the transducers datasheet
Max conductor size (see 12)	2,5 mm ²

Note: a maximum time of 800 ms (depending on communication type) have be considered between the driver energizing with the 24 Vdc power supply and when the valve is ready to operate. During this time the current to the valve coils is switched to zero.

6 CONNECTIONS AND LEDS

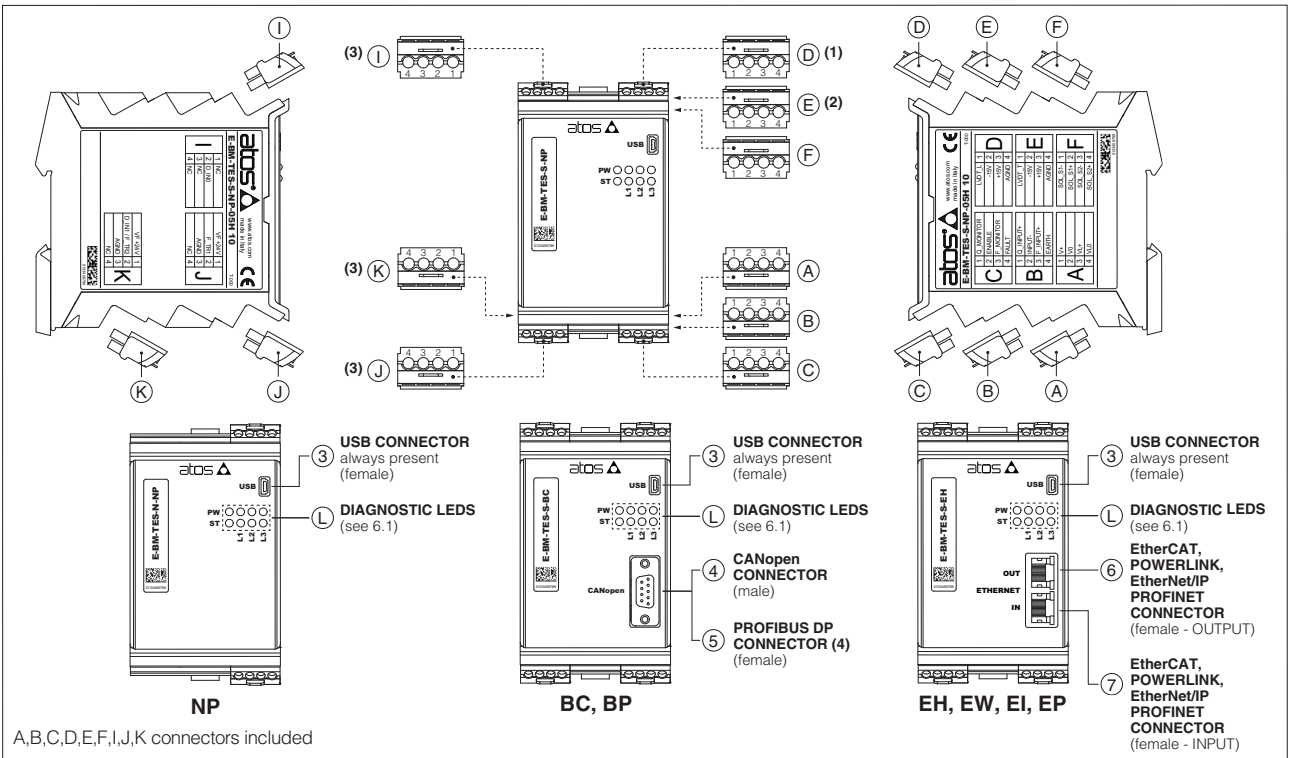

- (1) D connector is available only for TES-N versions 01HP / 05HP and LES-*
- (2) E connector is available only for TES-* versions 01H / 05H and LES-*
- (3) I, J and K connectors are available only for TES-S and LES-S

- (4) To interface with Siemens 6ES7972-0BA12-0XA connector, it is mandatory to use also one of the following adapters to avoid interference with the USB connector:
DG909MF1 - the connector will be oriented upwards
DG909MF3 - the connector will be oriented downwards

6.1 Diagnostic LEDs

Eight leds show driver operative conditions for immediate basic diagnostics. Please refer to the driver user manual for detailed information.

FIELDBUS LEDS	NP	BC	BP	EH	EW	EI	EP	PW	L1	L2	L3
L1	Not Present	VALVE STATUS		EtherCAT	LINK/ACT						
L2		NETWORK STATUS			NETWORK STATUS						
L3		SOLENOID STATUS			LINK/ACT						
PW	OFF = Power supply OFF	ON = Power supply ON									
ST	OFF = Fault present	ON = No fault									

6.2 Connectors - 4 pin

CONNECTOR	PIN	ALTERNATED P/Q CONTROL		TECHNICAL SPECIFICATIONS	NOTES
		N none	S pressure/force		
A	A1	V+		Power supply 24 Vdc (see 8.1)	Input - power supply
	A2	V0		Power supply 0 Vdc (see 8.1)	Gnd - power supply
	A3	VL+		Power supply 24 Vdc for driver's logic and communication (see 8.2)	Input - power supply
	A4	VLO		Power supply 0 Vdc for driver's logic and communication (see 8.2)	Gnd - power supply
B	B1	Q_INPUT+		Flow reference input signal: ± 10 Vdc / ± 20 mA maximum range Default are ± 10 Vdc for standard and $4 \div 20$ mA for /I option (see 8.3)	Input - analog signal Software selectable
	B2	INPUT-		Negative reference input signal for Q_INPUT+ and F_INPUT+	Input - analog signal
	B3	NC		Do not connect	
			F_INPUT+	Pressure/Force reference input signal ± 10 Vdc / ± 20 mA maximum range Default are ± 10 Vdc for standard and $4 \div 20$ mA for /I option (see 8.4)	Input - analog signal Software selectable
B4	EARTH		Connect to system ground		
C	C1	Q_MONITOR		Flow monitor output signal: ± 10 Vdc / ± 20 mA maximum range, referred to AGND. Default are ± 10 Vdc for standard and $4 \div 20$ mA for /I option (see 8.5)	Output - analog signal Software selectable
	C2	ENABLE		Enable (24 Vdc) or disable (0 Vdc) the controller, referred to VL0 (see 8.7)	Input - on/off signal
	C3	NC		Do not connect	
			F_MONITOR	Pressure/Force monitor output signal: ± 10 Vdc / ± 20 mA maximum range, referred to AGND Default are ± 10 Vdc for standard and $4 \div 20$ mA for /I option (see 8.6)	Output - analog signal Software selectable
C4	FAULT		Fault (0 Vdc) or normal working (24 Vdc), referred to VL0 (see 8.8)	Output - on/off signal	
D ⁽¹⁾	D1	LVDT_L		Main stage valve position transducer signal (see 8.9)	Input - analog signal
	D2	-15V		Main stage valve position transducer power supply -15V	Output power supply
	D3	+15V		Main stage valve position transducer power supply +15V	Output power supply
	D4	AGND		Common gnd for transducer power and monitor outputs	Common gnd
E ⁽²⁾	E1	LVDT_T		Direct valve or pilot valve position transducer signal (see 8.9)	Input - analog signal
	E2	-15V		Direct valve or pilot valve position transducer power supply -15V	Output power supply
	E3	+15V		Direct valve or pilot valve position transducer power supply +15V	Output power supply
	E4	AGND		Common gnd for transducer power and monitor outputs	Common gnd
F	F1	SOL_S1-		Negative current to solenoid S1	Output - power PWM
	F2	SOL_S1+		Positive current to solenoid S1	Output - power PWM
	F3	SOL_S2-		Negative current to solenoid S2	Output - power PWM
	F4	SOL_S2+		Positive current to solenoid S2	Output - power PWM
I	I1		NC	Do not connect	
	I2		D_IN0	NP execution: multiple pressure/force PID selection, referred to VL0 (see 8.11) Fieldbus execution: general purpose digital input $0 \div 24$ Vdc, referred to VL0 (see 8.11)	Input - on/off signal
	I3		NC	Do not connect	
	I4		NC	Do not connect	
J	J1		VF +24V	Power supply: +24Vdc or OFF (default OFF)	Output - power supply Software selectable
	J2		F_TR1	1st signal pressure/force transducer: ± 10 Vdc / ± 20 mA maximum range Default are ± 10 Vdc for standard and $4 \div 20$ mA for /C option (see 8.10)	Input - analog signal Software selectable
	J3		AGND	Common gnd for transducer power and signals	Common gnd
	J4		NC	Do not connect	
K	K1		VF +24V	Power supply: +24Vdc or OFF (default OFF)	Output - power supply Software selectable
	K2		F_TR2	2nd signal pressure transducer (only for SF): ± 10 Vdc / ± 20 mA maximum range Default are ± 10 Vdc for standard and $4 \div 20$ mA for /C option (see 8.10)	Input - analog signal Software selectable
			D_IN1	NP execution: multiple pressure/force PID selection (only for SP and SL), referred to VL0 (see 8.11) Fieldbus execution: general purpose digital input $0 \div 24$ Vdc, referred to VL0 (see 8.11)	Input - on/off signal
	K3		AGND	Common gnd for transducer power and signals	Common gnd
K4		NC	Do not connect		

(1) D connector is available only for TES-N versions 01HP / 05HP and LES-*

(2) E connector is available only for TES-* versions 01H / 05H and LES-*

6.3 Pressure/force transducers connection - example - only for S option

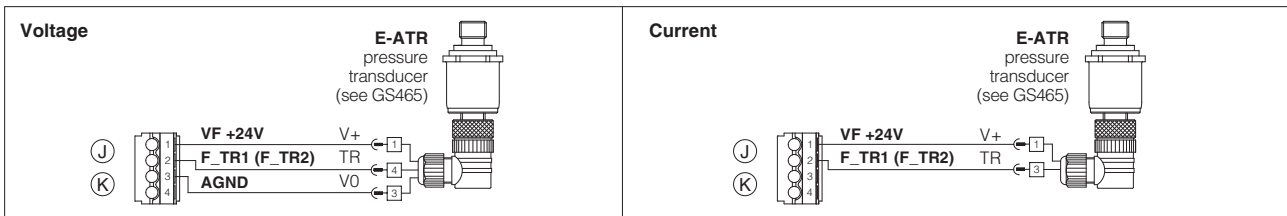

6.4 Communication connectors ③ - ④ - ⑤ - ⑥ - ⑦

③ USB connector - Mini USB type B always present		
PIN	SIGNAL	TECHNICAL SPECIFICATION (1)
1	+5V_USB	Power supply
2	D-	Data line -
3	D+	Data line +
4	ID	Identification
5	GND_USB	Signal zero data line

④ BC fieldbus execution, connector - DB9 - 9 pin		
PIN	SIGNAL	TECHNICAL SPECIFICATION (1)
2	CAN_L	Bus line (low)
3	CAN_GND	Signal zero data line
5	CAN_SHLD	Shield
7	CAN_H	Bus line (high)

⑤ BP fieldbus execution, connector - DB9 - 9 pin		
PIN	SIGNAL	TECHNICAL SPECIFICATION (1)
1	SHIELD	
3	LINE-B	Bus line (low)
5	DGND	Data line and termination signal zero
6	+5V	Termination supply signal
8	LINE-A	Bus line (high)

⑥ ⑦ EH, EW, EI, EP fieldbus execution, connector - RJ45 - 8 pin		
PIN	SIGNAL	TECHNICAL SPECIFICATION (1)
1	TX+	Transmitter - white/orange
2	RX+	Receiver - white/green
3	TX-	Transmitter - orange
6	RX-	Receiver - green

(1) shield connection on connector's housing is recommended

7 SET CODE

The basic calibration of electronic driver is factory preset, according to the proportional valve to be coupled. These pre-calibrations are identified by the set code at the end of driver's model code (see section 1). For correct set code selection, please include in the driver order also the complete code of the coupled proportional valve. For further information about set code, please contact Atos technical office.

8 POWER SUPPLY AND SIGNALS SPECIFICATIONS

Atos digital drivers are CE marked according to the applicable directives (e.g. Immunity and Emission EMC Directive).

Installation, wirings and start-up procedures must be performed according to the general prescriptions shown in tech table FS900 and in the user manuals included in the E-SW-* programming software.

Generic electrical output signals of the valve (e.g. fault or monitor signals) must not be directly used to activate safety functions, like to switch-ON/OFF the machine's safety components, as prescribed by the European standards (Safety requirements of fluid technology systems and components-hydraulics, ISO 4413).

8.1 Power supply (V+ and V0)

The power supply (pin A1 and A2) must be appropriately stabilized or rectified and filtered: apply at least a 10000 μ F/40 V capacitance to single phase rectifiers or a 4700 μ F/40 V capacitance to three phase rectifiers.

 A safety fuse is required in series to each power supply: 2,5 A time lag fuse.

8.2 Power supply for driver's logic and communication (VL+ and VL0)

The power supply (pin A3 and A4) for driver's logic and communication must be appropriately stabilized or rectified and filtered: apply at least a 10000 μ F/40 V capacitance to single phase rectifiers or a 4700 μ F/40 V capacitance to three phase rectifiers.

The separate power supply for driver's logic, allow to remove solenoid power supply from pin A1 and A2 maintaining active the diagnostics, USB and fieldbus communications.

 A safety fuse is required in series to each driver's logic and communication power supply: 500 mA fast fuse.

8.3 Flow reference input signals (Q_INPUT+)

The driver is designed to receive an analog reference input signal (pin B1) for the valve's spool position.

Reference input signal is factory preset according to selected valve code, defaults are ± 10 V_{DC} for standard and $4 \div 20$ mA for I option.

Input signal can be reconfigured via software selecting between voltage and current, within a maximum range of ± 10 V_{DC} or ± 20 mA.

Drivers with fieldbus interface can be software set to receive reference signal directly by the machine control unit (fieldbus reference).

Analog reference input signal can be used as on-off commands with input range $0 \div 24$ V_{DC}.

8.4 Pressure or force reference input signal (F_INPUT+) - only for S option

Functionality of pressure or force input reference signal (pin B3), is used as reference for the driver pressure/force closed loop, see section 4.

Reference input signal is factory preset according to selected valve code, defaults are ± 10 V_{DC} for standard and $4 \div 20$ mA for I option.

Input signal can be reconfigured via software selecting between voltage and current, within a maximum range of ± 10 V_{DC} or ± 20 mA.

Drivers with fieldbus interface can be software set to receive reference signal directly by the machine control unit (fieldbus reference).

Analog reference input signal can be used as on-off commands with input range $0 \div 24$ V_{DC}.

8.5 Flow monitor output signal (Q_MONITOR)

The driver generates an analog output signal (pin C1) proportional to the actual spool position; the monitor output signal can be software set to show other signals available in the driver (e.g. analog reference, fieldbus reference, valve spool position). Monitor output signal is factory preset according to selected valve code, defaults are ± 10 VDC for standard and $4 \div 20$ mA for /I option. Output signal can be reconfigured via software selecting between voltage and current, within a maximum range of ± 10 Vdc or ± 20 mA.

8.6 Pressure or force monitor output signal (F_MONITOR) - only for S option

The driver generates an analog output signal (C3) proportional to alternated pressure/force control; the monitor output signal can be software set to show other signals available in the driver (e.g. analog reference, force reference). Monitor output signal is factory preset according to selected valve code, defaults are ± 10 Vdc for standard and $4 \div 20$ mA for /I option. Output signal can be reconfigured via software selecting between voltage and current, within a maximum range of ± 10 Vdc or ± 20 mA.

8.7 Enable input signal (ENABLE)

To enable the driver, supply 24 Vdc on pin C2: Enable input signal allows to enable/disable the current supply to the solenoid, without removing the electrical power supply to the driver; it is used to active the communication and the other driver functions when the valve must be disabled for safety reasons. This condition **does not comply** with norms IEC 61508 and ISO 13849. Enable input signal can be used as digital input by software selection.

8.8 Fault output signal (FAULT)

Fault output signal (pin C4) indicates fault conditions of the driver (solenoid short circuits/not connected, reference or transducer signal cable broken, maximum error exceeded, etc.). Fault presence corresponds to 0 Vdc, normal working corresponds to 24 Vdc. Fault status is not affected by the status of the Enable input signal. Fault output signal can be used as digital output by software selection.

8.9 Main stage and direct or pilot position transducer input signals (LVDT_L and LVDT_T)

Main stage (LVDT_L pin D1) and direct or pilot (LVDT_T pin E1) position transducer integrated to the valve have to be directly connected to the driver using ± 15 Vdc supply output available at pin D2, D3 and pin E2, E3. Note: transducer input signals working range is ± 10 Vdc for standard or $4 \div 20$ mA for /C option and **cannot** be reconfigured via software (input signals setting depends to the driver set code).

8.10 Remote pressure/force transducer input signals (F_TR1 and F_TR2) - only for S option

Analog remote pressure transducers or load cell can be directly connected to the driver. Analog input signal is factory preset according to selected driver code, defaults are ± 10 Vdc for standard and $4 \div 20$ mA for /C option. Input signal can be reconfigured via software selecting between voltage and current, within a maximum range of ± 10 Vdc or ± 20 mA. Refer to pressure/force transducer characteristics to select the transducer type according to specific application requirements (see tech table **FS500**).

8.11 Multiple PID selection or digital input signals (D_IN0 and D_IN1) - only for S option

Two on-off input signals are available on the connectors I and K. For NP executions pin I2 and/or pin K2 are used to select one of the four pressure (force) PID parameters setting, stored into the driver. Switching the active setting of pressure PID during the machine cycle allows to optimize the system dynamic response in different hydraulic working conditions (volume, flow, etc.). Supply a 24 Vdc or a 0 Vdc on pin I2 and/or pin K2, to select one of the PID settings as indicated by binary code table at side. Gray code can be selected by software. For fieldbus executions pin I2 and/or K2 can be used as generic purpose on-off input signals.

PIN	PID SET SELECTION			
	SET 1	SET 2	SET 3	SET 4
I2	0	24 Vdc	0	24 Vdc
K2	0	0	24 Vdc	24 Vdc

8.12 Possible combined options: /AC, /AI, /ACI, /CI - combined options /CI is available only for E-BM-TES/LES-S.

9 VALVE SETTINGS AND PROGRAMMING TOOLS

Valve's functional parameters and configurations, can be easily set and optimized using Atos E-SW programming software connected via USB port to the digital driver (see table **FS900**). For fieldbus versions, the software permits valve's parameterization through USB port also if the driver is connected to the central machine unit via fieldbus.

The software is available in different versions according to the driver's options (see table **GS500**):

E-SW-BASIC support: NP (USB) PS (Serial) IR (Infrared)
E-SW-FIELDBUS support: BC (CANopen) BP (PROFIBUS DP) EH (EtherCAT)
 EW (POWERLINK) EI (EtherNet/IP) EP (PROFINET)
E-SW-*/PQ support: valves with SP, SF, SL alternated control (e.g. E-SW-BASIC/PQ)

WARNING: drivers USB port is not isolated! For E-C-SB-USB/BM cable, the use of isolator adapter is highly recommended for PC protection

WARNING: see tech table **GS500** for the list of countries where the Bluetooth adapter has been approved

Free programming software, web download:

E-SW-BASIC web download = software can be downloaded upon web registration at www.atos.com; service and DVD not included
 Upon web registration user receive via email the Activation Code (software free license) and login data to access Atos Download Area

DVD programming software, to be ordered separately:

E-SW-*/PQ DVD first supply = software has to be activated via web registration at www.atos.com; 1 year service included
 Upon web registration user receive via email the Activation Code (software license) and login data to access Atos Download Area

E-SW-*/N/PQ DVD next supplies = only for supplies after the first; service not included, web registration not allowed
 Software has to be activated with Activation Code received upon first supply web registration

Atos Download Area: direct access to latest releases of E-SW software, manuals, USB drivers and fieldbus configuration files at www.atos.com

USB Adapters, Cables and Terminators, can be ordered separately

USB or Bluetooth connection

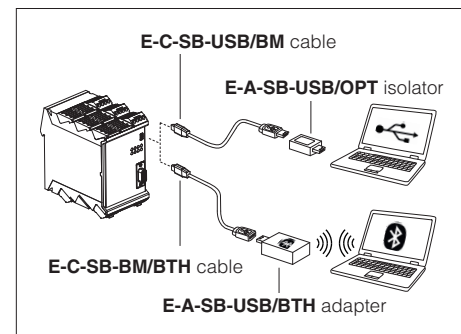

10 MAIN SOFTWARE PARAMETER SETTINGS

For basic information about main setting parameters by E-SW programming software, see tech table **FS900**

For detailed descriptions of settings, wirings and installation procedures, please refer to the user manual included in the E-SW programming software:

E-MAN-BM-LES - user manual for **E-BM-TES-N** and **E-BM-LES-N** digital drivers
E-MAN-BM-LES-S - user manual for **E-BM-TES-S** and **E-BM-LES-S** digital drivers

11 OVERALL DIMENSIONS [mm]

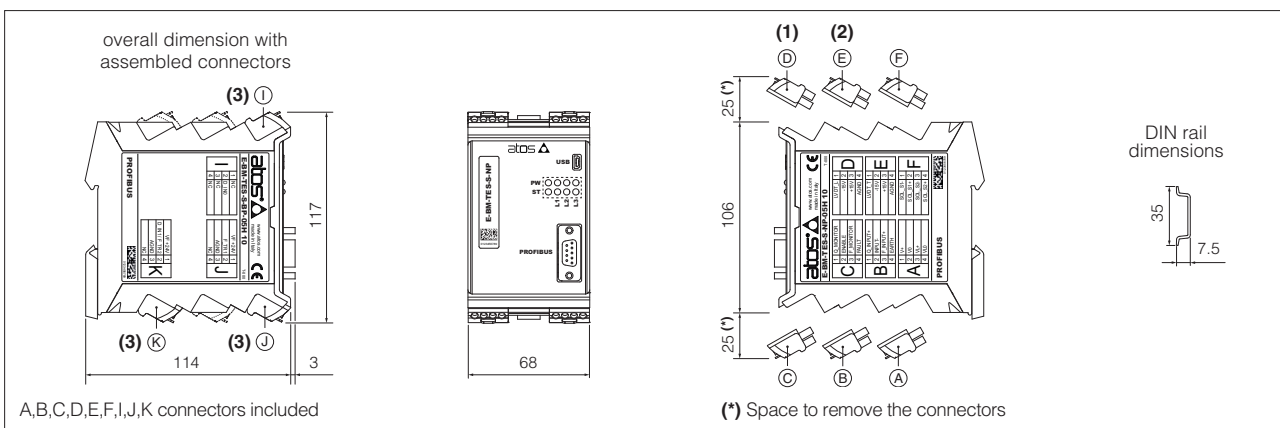

(1) D connector is available only for TES-N versions 01HP / 05HP and LES-*

(2) E connector is available only for TES-* versions 01H / 05H and LES-*

(3) I, J and K connectors are available only for TES-S and LES-S

12 INSTALLATION

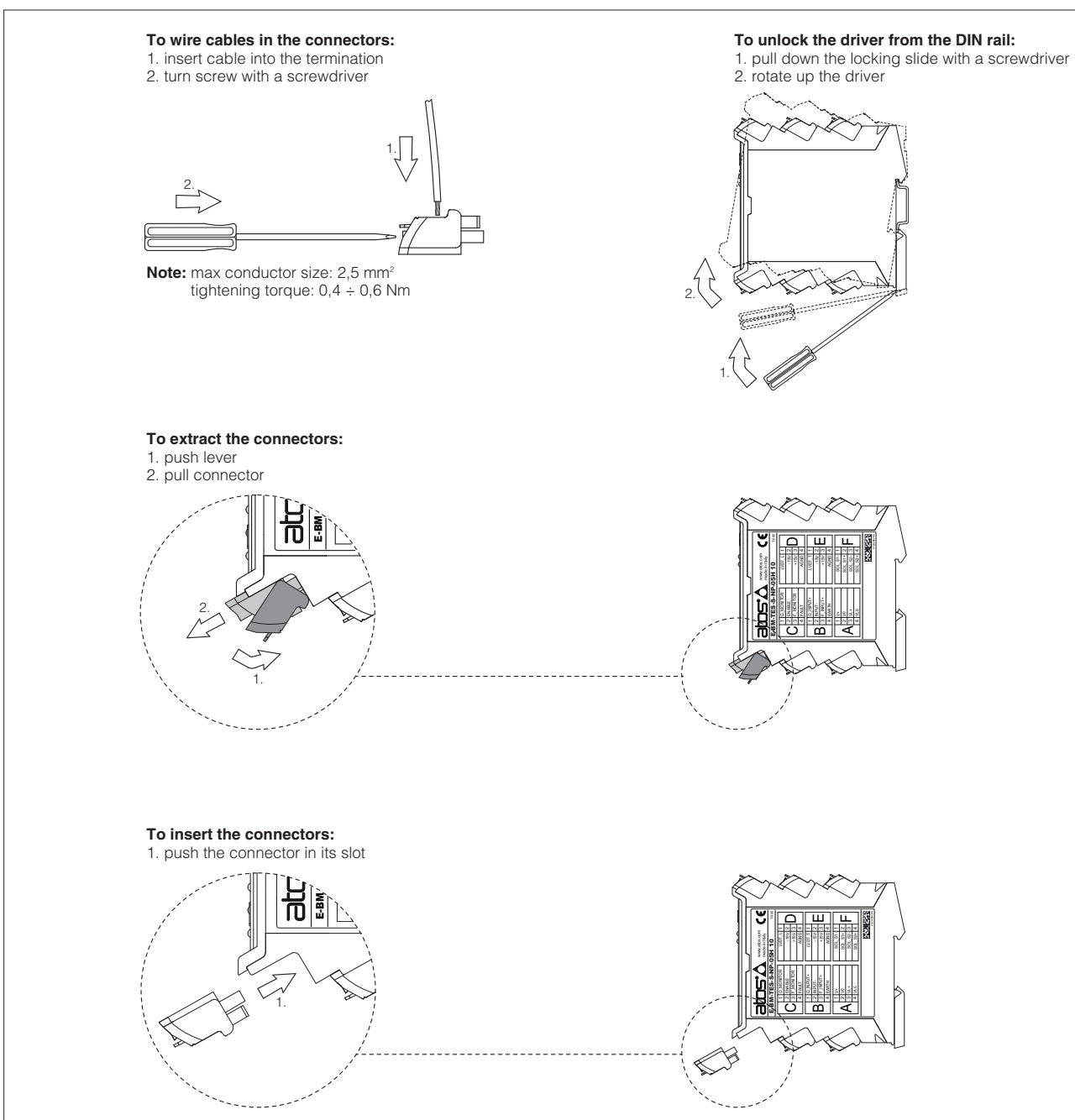

Note: all connectors are supplied with a mechanical coding. This feature ensures a unique insertion of each connector in the own slot. (e.g. connector A can not be inserted into connector slot of B,C,D,E,F,I,J,K)